

PHC C2060HX5M SKF

Double pitch conveyor chain

TYPE: Conveyor chain, Double pitch, roller (SKF)

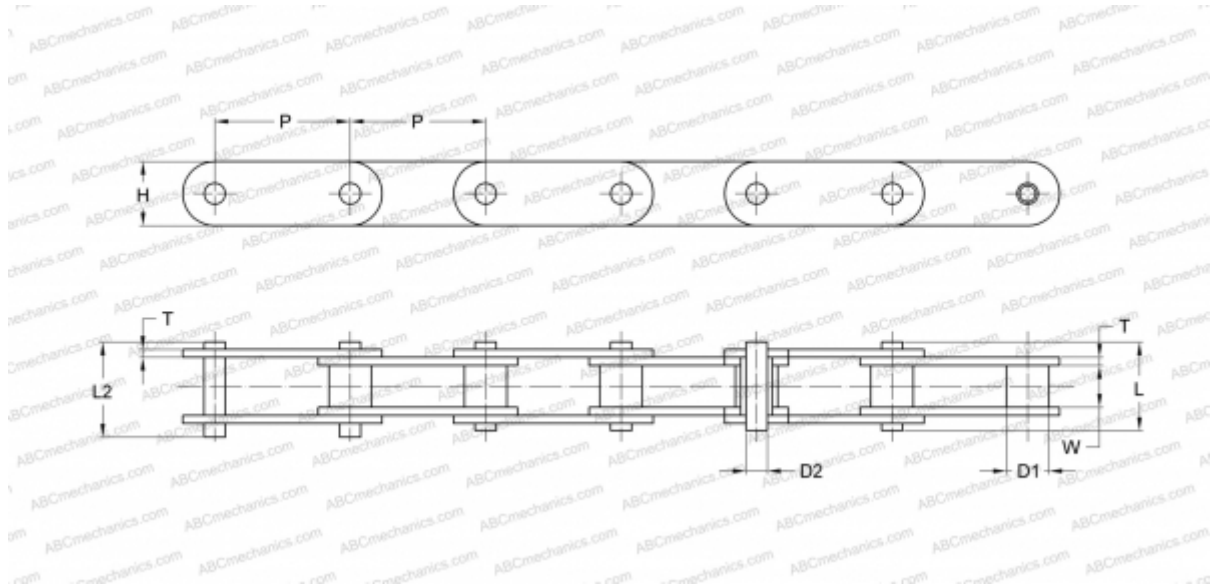

Technical specification

DIMENSIONS, MM

P	38,100
D1	11,910
W	12,570
D2	5,940
H	18,000
T	3,250
L	29,200
L2	31,600

WEIGHT, KG/M 1,440

MANUFACTURER [SKF](#)

DESIGNATION BS/ISO: C212AH

DESIGNATION ANSI: C2060H