

## PHC C2080HX10FT SKF

Double pitch conveyor chain

TYPE: Conveyor chain, Double pitch, roller (SKF)

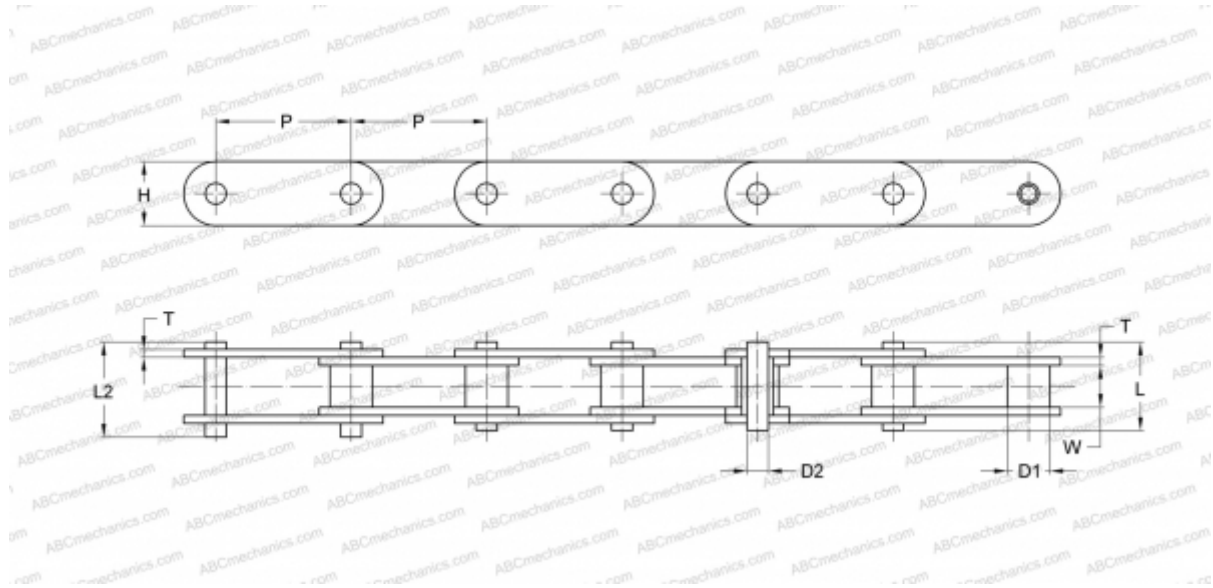

### Technical specification

#### DIMENSIONS, MM

P	50,800
D1	15,880
W	15,750
D2	7,920
H	24,000
T	4,000
L	36,200
L2	39,400

**WEIGHT, KG/M** 2,540

**MANUFACTURER** [SKF](#)

**DESIGNATION BS/ISO:** C216AH

**DESIGNATION ANSI:** C2080H