

PHC 81XHHX10FT SKF

Conveyor chain

TYPE: Conveyor chains for special use, Lumber mill series, SKF

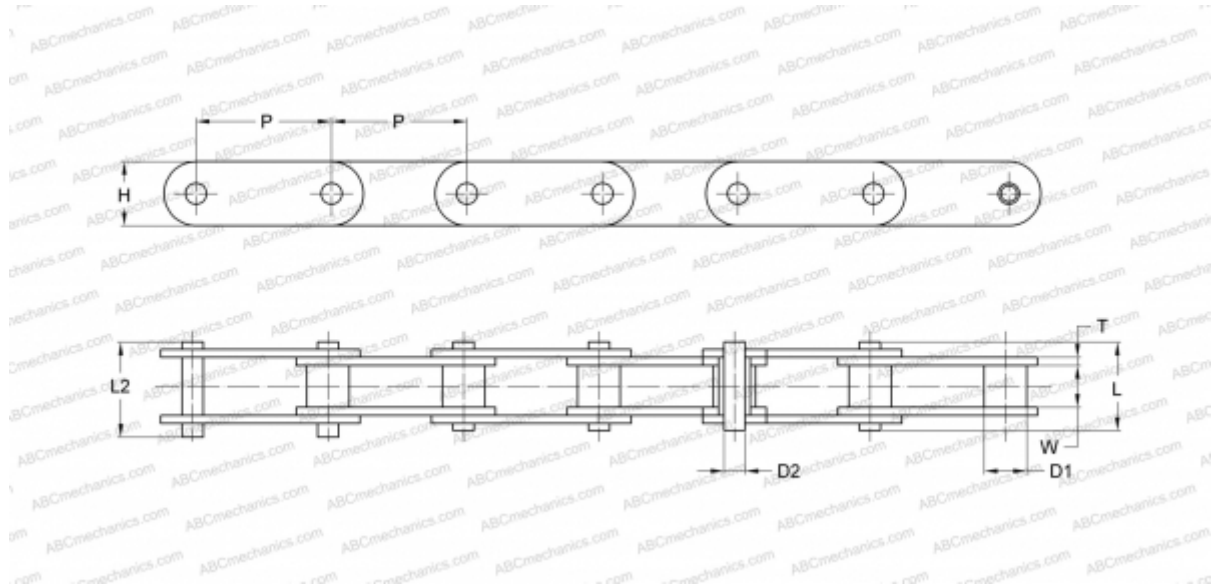

Technical specification

DIMENSIONS, MM

P	66,270
D1	23,000
W	27,780
D2	11,100
H	31,350
T	7,940
L	65,600
L2	70,000

WEIGHT, KG/M 6,700

MANUFACTURER [SKF](#)

DESIGNATION BS/ISO: 81XHH