

PHC 81XHSX10FT SKF

Conveyor chain

TYPE: Conveyor chains for special use, Lumber mill series, SKF

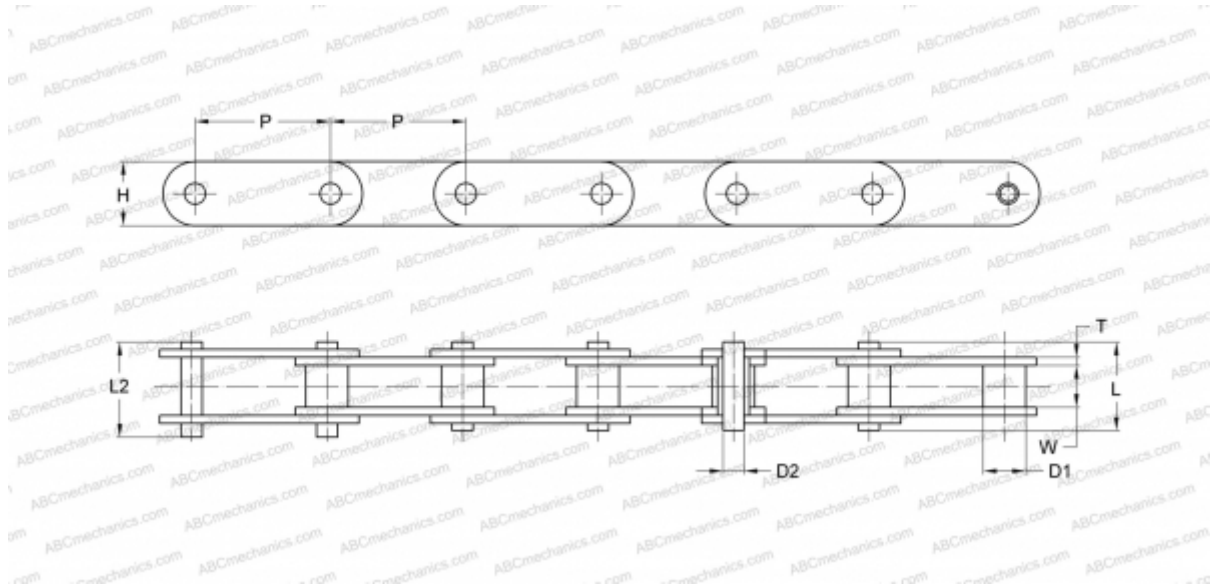

Technical specification

DIMENSIONS, MM

P	66,270
D1	23,000
W	27,000
D2	11,100
H	31,800
T	7,600
L	63,600
L2	68,000

WEIGHT, KG/M 6,550

MANUFACTURER [SKF](#)

DESIGNATION BS/ISO: 81XHS