

## PHC 441.100RX10FT SKF

Conveyor chain

TYPE: Conveyor chains for special use, Lumber mill series, SKF

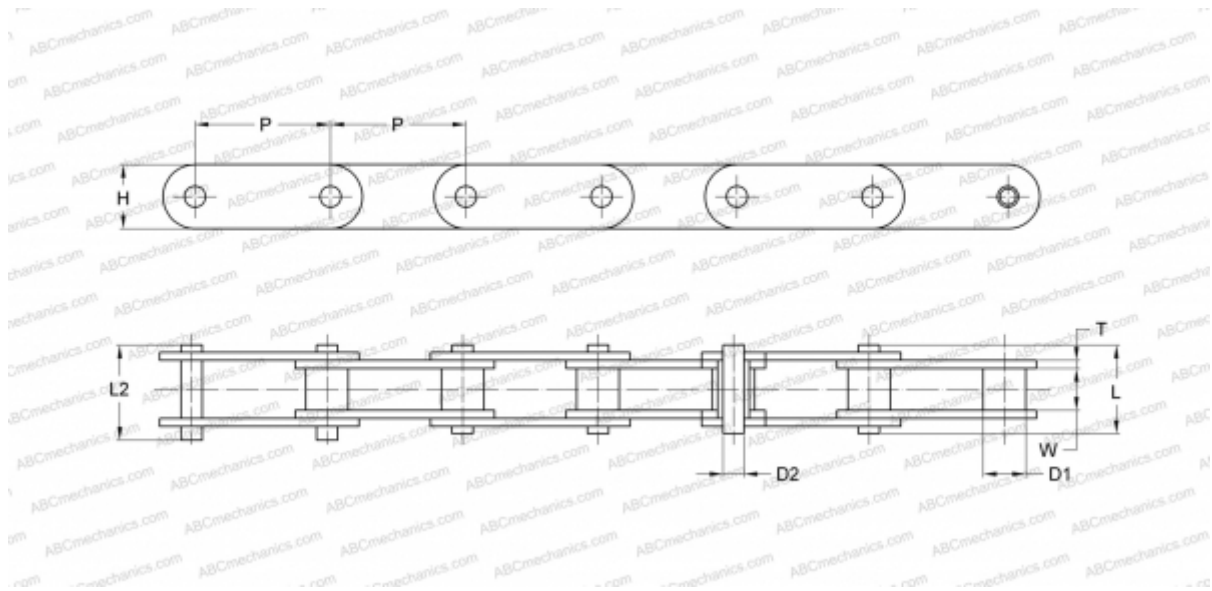

### Technical specification

#### DIMENSIONS, MM

P	100,000
D1	25,400
W	25,400
D2	14,630
H	40,000
T	5,000
L	52,000
L2	56,400

**WEIGHT, KG/M** 5,150

**MANUFACTURER** [SKF](#)

**DESIGNATION BS/ISO:** 441.100R