

## LAH15AN NSK

Linear guides

TYPE: Monorail guidance systems, Recirculating balls, High vertical load carrying capacity type, Self-aligning type, Square type, High, Ball slide length - standard, Mounting tap, Interchangeable part

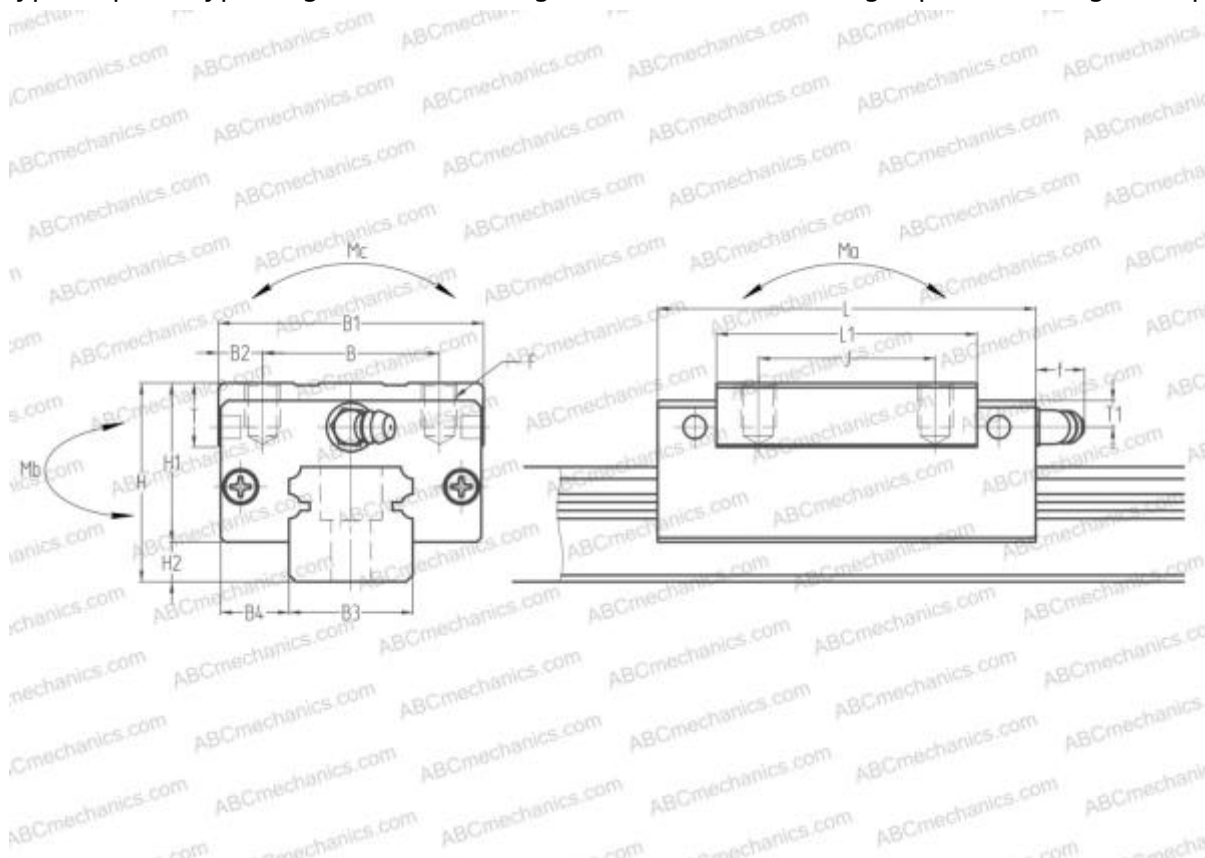

### Technical specification

#### DIMENSIONS, MM

|    |          |
|----|----------|
| B1 | 34,000   |
| H  | 28,000   |
| L  | 55,000   |
| B  | 26,000   |
| J  | 26,000   |
| L1 | 39,000   |
| B2 | 4,000    |
| B3 | 15,000   |
| B4 | 9,500    |
| H1 | 23,400   |
| H2 | 4,600    |
| T  | 8,000    |
| T1 | 8,500    |
| f  | 3,300    |
| F  | M4x0.7x6 |

#### SLIDE WEIGHT

0,180

#### MANUFACTURER

[NSK](#)

#### CALCULATION DATA

|                               |            |
|-------------------------------|------------|
| Basic dynamic load rating, C  | 10,800 kN  |
| Basic static load rating, Co  | 20,700 kN  |
| Static permissible moment, Ma | 0,095 kN-m |
| Static permissible moment, Mb | 0,080 kN-m |
| Static permissible moment, Mc | 0,108 kN-m |