

SH25BN NSK

Linear guides

TYPE: Monorail guidance systems, Recirculating balls, High vertical load carrying capacity type, Self-aligning type, Square type, High, Ball slide length - long, Mounting tap, Low noise, smooth operation type, Interchangeable part

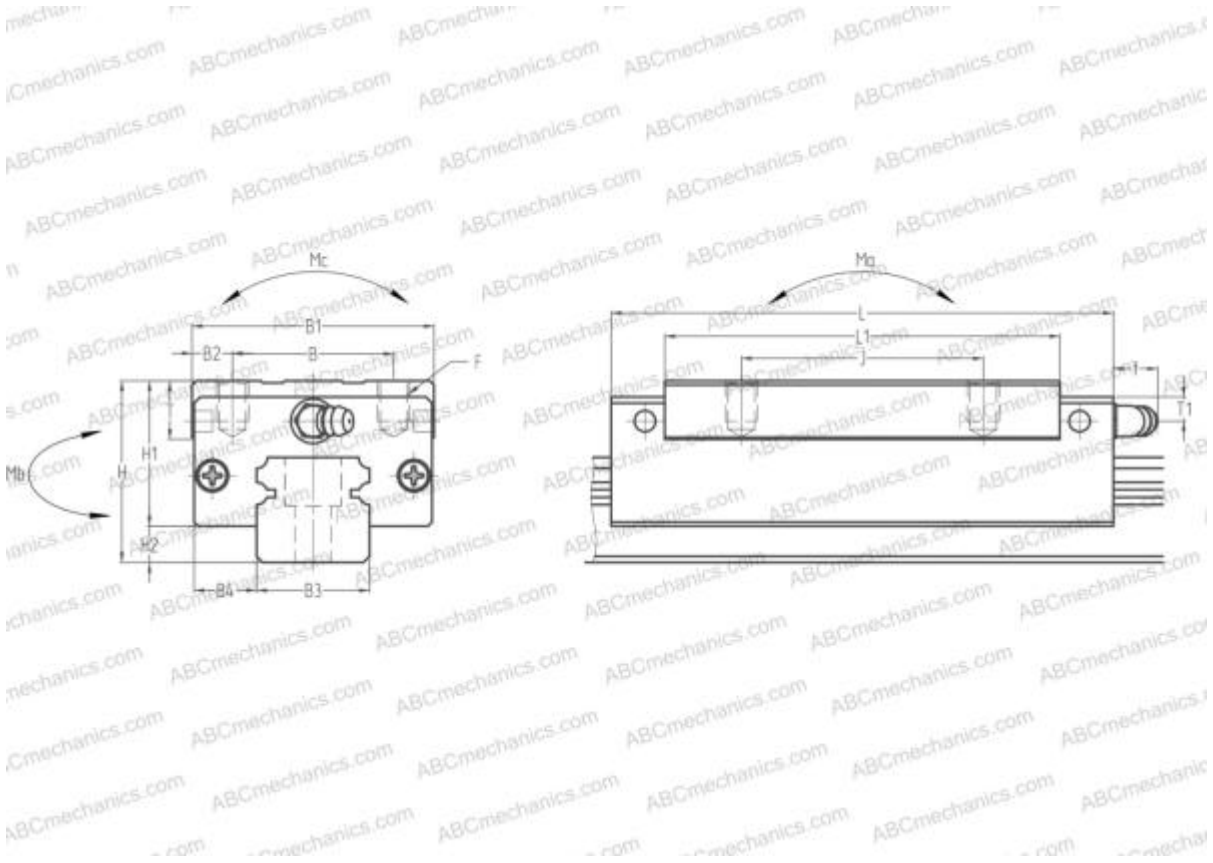

Technical specification

DIMENSIONS, MM

B1	48,000
H	40,000
L	107,000
B	35,000
J	50,000
L1	86,000
D2	11,500
B2	6,500
B3	23,000
B4	12,500
H1	33,000
H2	7,000
T	12,000
T1	10,000
f	11,000

CALCULATION DATA

Basic static load rating, C_0	62,500 kN
Static permissible moment, M_a	0,615 kN-m
Static permissible moment, M_b	0,515 kN-m
Static permissible moment, M_c	0,490 kN-m

INCLUDED PRODUCTS

SAH25BN

DIMENSIONS, MM

C	60,000
d1	7,000
d2	11,000
h	22,000
h1	9,000
L max	3860,000
aL	20,000
aR	20,000
F	M6x1x9

WEIGHT

Slide weight	0,820
Rail weight	3,600

MANUFACTURER[NSK](#)**CALCULATION DATA**

Basic dynamic load rating, C	32,000 kN
------------------------------	-----------