

SH45BN NSK

Linear guides

TYPE: Monorail guidance systems, Recirculating balls, High vertical load carrying capacity type, Self-aligning type, Square type, High, Ball slide length - long, Mounting tap, Low noise, smooth operation type, Interchangeable part

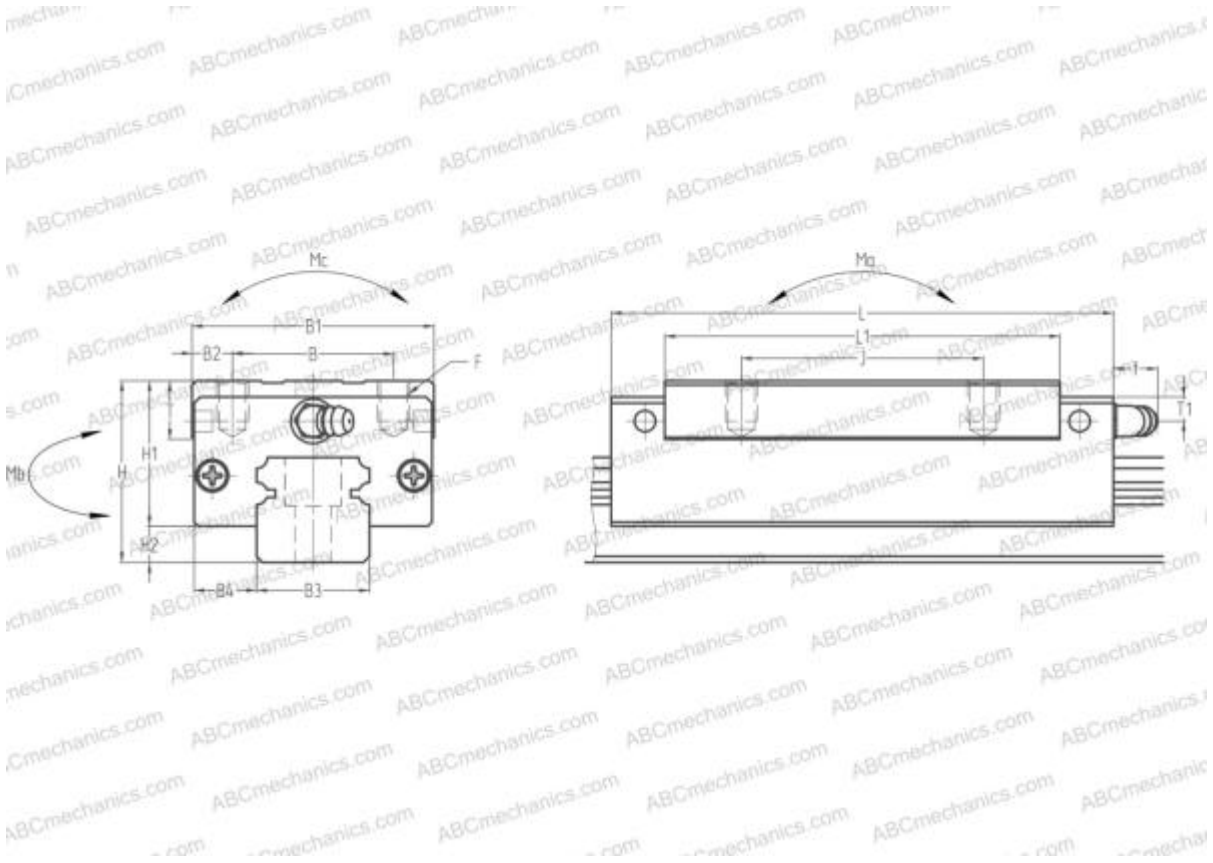

Technical specification

DIMENSIONS, MM

B1	86,000
H	70,000
L	171,000
B	60,000
J	80,000
L1	137,000
D2	22,500
B2	13,000
B3	45,000
B4	20,500
H1	56,000
H2	14,000
T	17,000
T1	20,000
f	13,000

CALCULATION DATA

Basic static load rating, C_0	175,000 kN
Static permissible moment, M_a	2,760 kN-m
Static permissible moment, M_b	2,320 kN-m
Static permissible moment, M_c	2,680 kN-m

INCLUDED PRODUCTS

SAH45BN

DIMENSIONS, MM

C	105,000
d1	14,000
d2	20,000
h	38,000
h1	17,000
L max	3990,000
aL	22,500
aR	22,500
F	M10x1.5x17

WEIGHT

Slide weight	3,900
Rail weight	12,300

MANUFACTURER

[NSK](#)

CALCULATION DATA

Basic dynamic load rating, C	94,500 kN
------------------------------	-----------