

SH55BN NSK

Linear guides

TYPE: Monorail guidance systems, Recirculating balls, High vertical load carrying capacity type, Self-aligning type, Square type, High, Ball slide length - long, Mounting tap, Low noise, smooth operation type, Interchangeable part

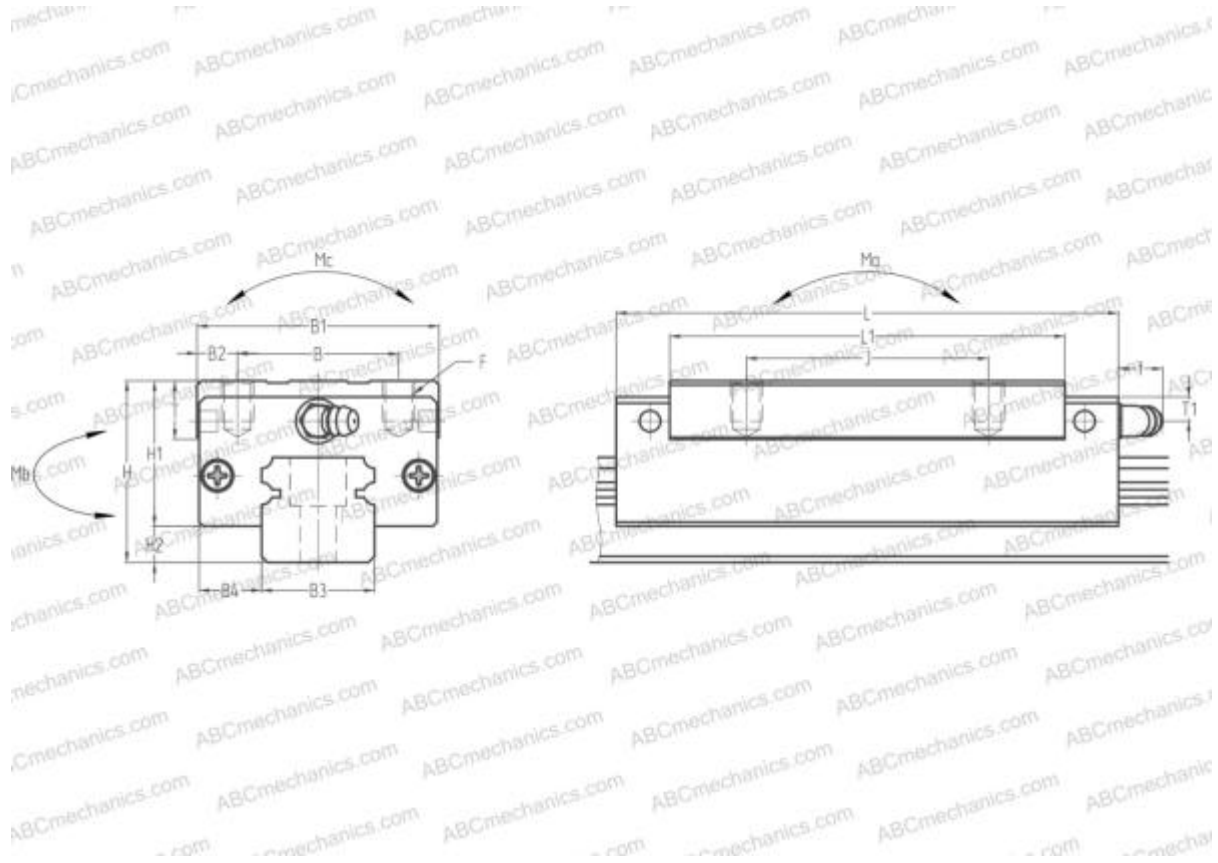

Technical specification



DIMENSIONS, MM

B1	100,000
H	80,000
L	201,000
B	75,000
J	95,000
L1	164,000
D2	26,500
B2	12,500
B3	53,000
B4	23,500
H1	65,000
H2	15,000
T	18,000
T1	21,000
f	13,000

CALCULATION DATA

Basic static load rating, C_0	247,000 kN
Static permissible moment, M_a	4,800 kN-m
Static permissible moment, M_b	4,050 kN-m
Static permissible moment, M_c	4,550 kN-m

INCLUDED PRODUCTS

SAH55BN

DIMENSIONS, MM

C	120,000
d1	16,000
d2	23,000
h	44,000
h1	20,000
L max	3990,000
aL	30,000
aR	30,000
F	M12x1.75x18

WEIGHT

Slide weight	6,100
Rail weight	16,900

MANUFACTURER

[NSK](#)

CALCULATION DATA

Basic dynamic load rating, C	140,000 kN
------------------------------	------------

