

SS15CL NSK

Linear guides

TYPE: Monorail guidance systems, Recirculating balls, High vertical load carrying capacity type, Self-aligning type, Square type, Low, Ball slide length - short, Mounting tap, Low noise, smooth operation type

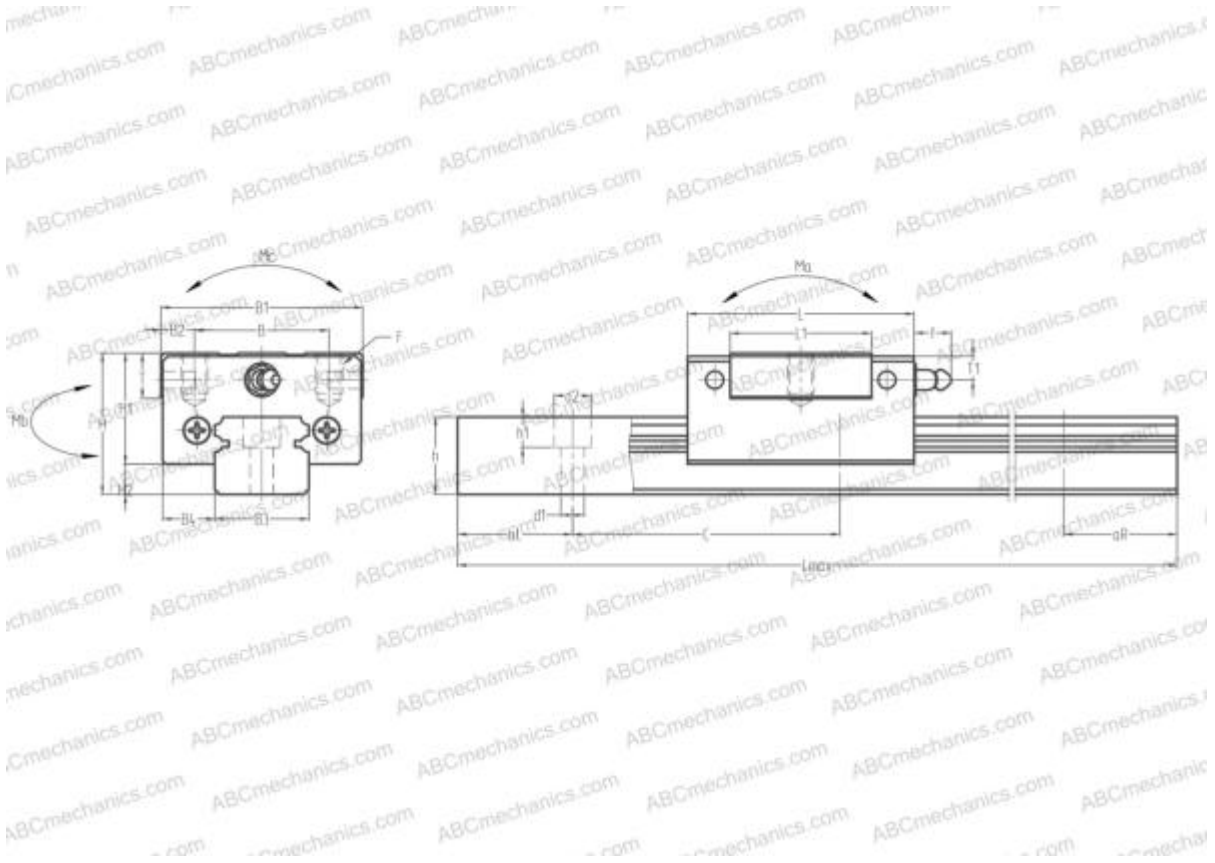

Technical specification



DIMENSIONS, MM

B1	34,000
H	24,000
L	40,400
B	26,000
L1	23,600
D2	7,500
B2	4,000
B3	15,000
B4	9,500
H1	19,400
H2	4,600
T	10,000
T1	6,000
f	3,000
C	60,000

CALCULATION DATA

Basic dynamic load rating, C	4,900 kN
Basic static load rating, Co	7,800 kN
Static permissible moment, Ma	0,021 kN-m
Static permissible moment, Mb	0,018 kN-m
Static permissible moment, Mc	0,039 kN-m

INCLUDED PRODUCTS

SAS15CL

DIMENSIONS, MM

d1	3,500
d2	6,000
h	12,500
h1	4,500
L max	2000,000
aL	20,000
aR	20,000
F	M4x0.7x6

WEIGHT

Slide weight	0,140
Rail weight	1,400

MANUFACTURER

[NSK](#)

INTERCHANGE

ABC	SS15CL
THK	SSR15XVY

