

SAS20CL NSK

Linear guides

TYPE: Monorail guidance systems, Recirculating balls, High vertical load carrying capacity type, Self-aligning type, Square type, Low, Ball slide length - short, Mounting tap, Low noise, smooth operation type, Interchangeable part

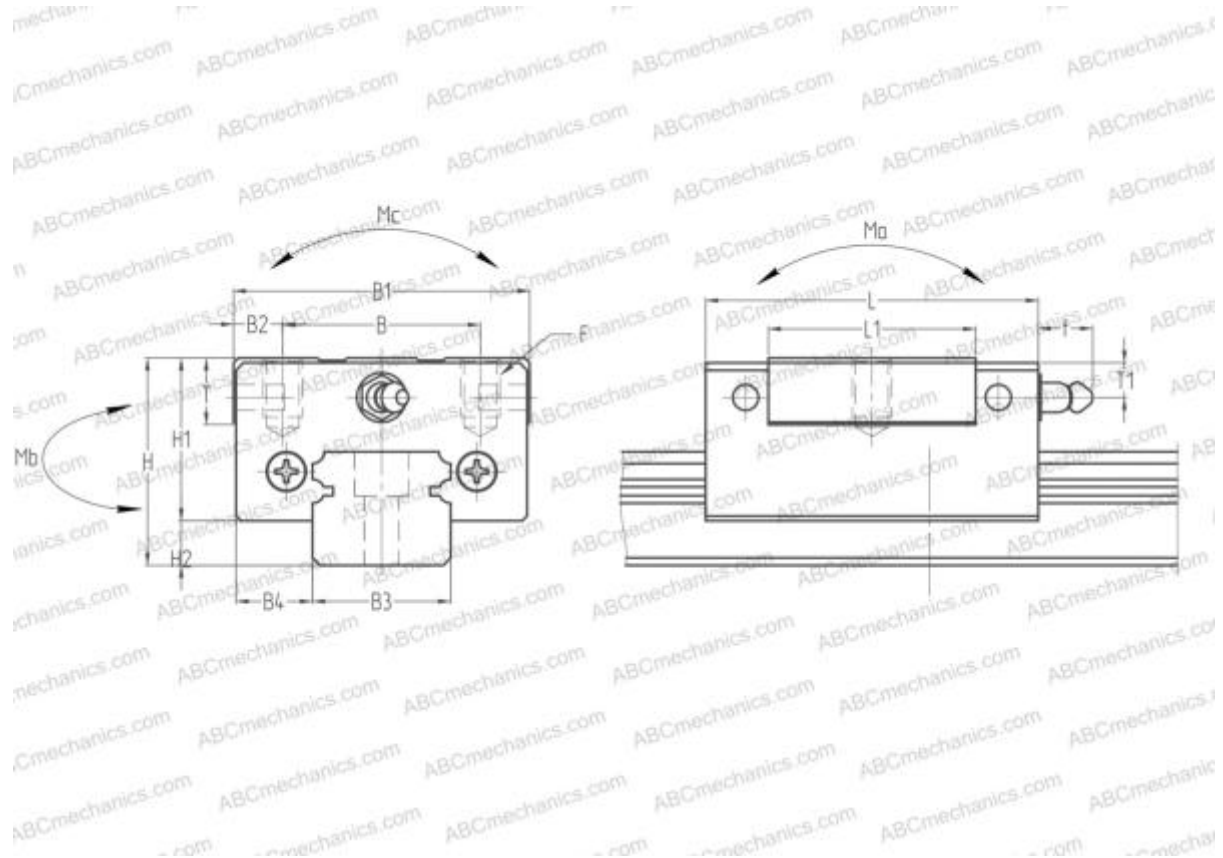

Technical specification

DIMENSIONS, MM

B1	42,000
H	28,000
L	47,200
B	32,000
L1	30,000
D2	10,000
B2	5,000
B3	20,000
B4	11,000
H1	22,000
H2	6,000
T	12,000
T1	5,500
f	11,000
F	M5x0.8x7

SLIDE WEIGHT

0,190

MANUFACTURER

[NSK](#)

CALCULATION DATA

Basic dynamic load rating, C	7,250 kN
Basic static load rating, Co	11,800 kN
Static permissible moment, Ma	0,041 kN-m
Static permissible moment, Mb	0,034 kN-m
Static permissible moment, Mc	0,080 kN-m