

SAS30CL NSK

Linear guides

TYPE: Monorail guidance systems, Recirculating balls, High vertical load carrying capacity type, Self-aligning type, Square type, Low, Ball slide length - short, Mounting tap, Low noise, smooth operation type, Interchangeable part

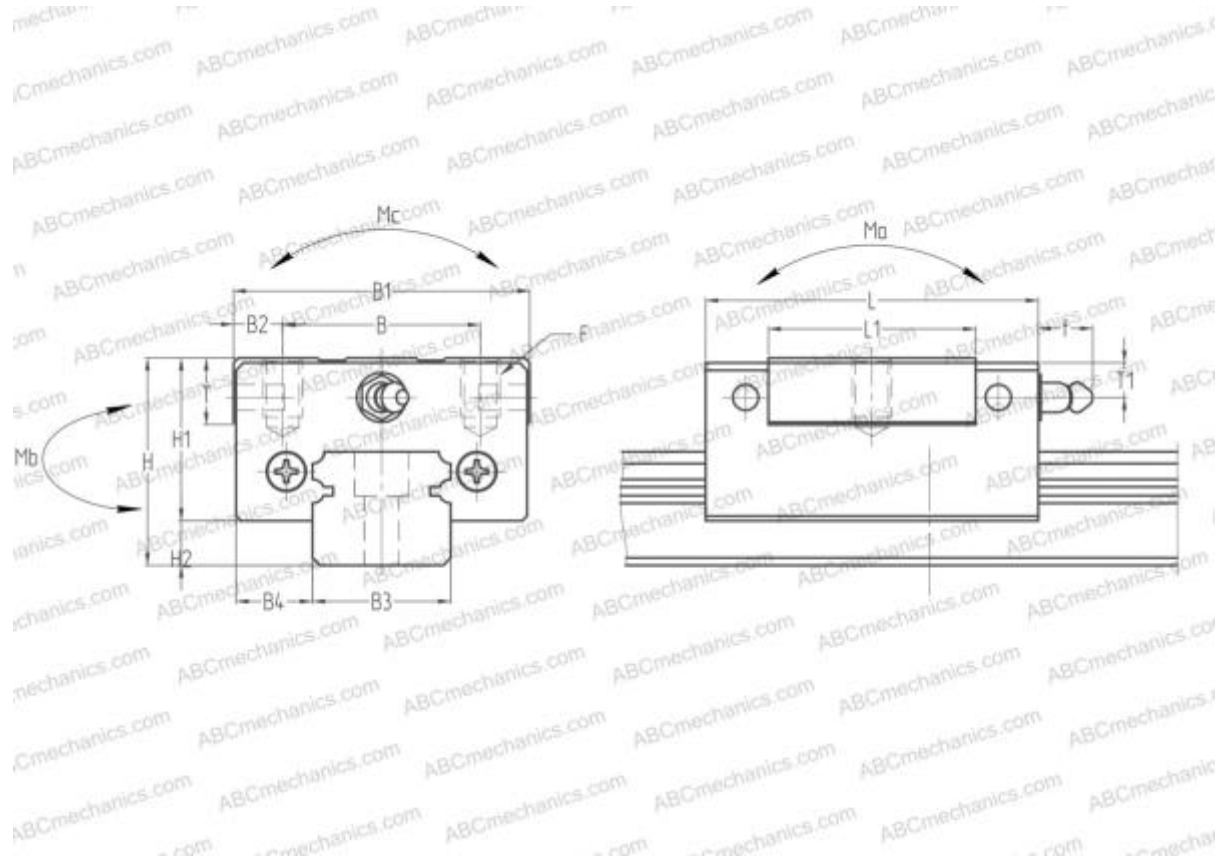

Technical specification

DIMENSIONS, MM

B1	60,000
H	42,000
L	67,400
B	40,000
L1	42,000
D2	14,000
B2	10,000
B3	28,000
B4	16,000
H1	33,000
H2	9,000
T	13,000
T1	8,000
f	11,000
F	M8x1.25x12

SLIDE WEIGHT

0,580

MANUFACTURER

[NSK](#)

CALCULATION DATA

Basic dynamic load rating, C	18,700 kN
Basic static load rating, Co	29,600 kN
Static permissible moment, Ma	0,153 kN-m
Static permissible moment, Mb	0,128 kN-m
Static permissible moment, Mc	0,282 kN-m