

LAH15EL NSK

Linear guides

TYPE: Monorail guidance systems, Recirculating balls, High vertical load carrying capacity type, Self-aligning type, Flanged type, Low, Ball slide length - standard, Mounting tap, Interchangeable part

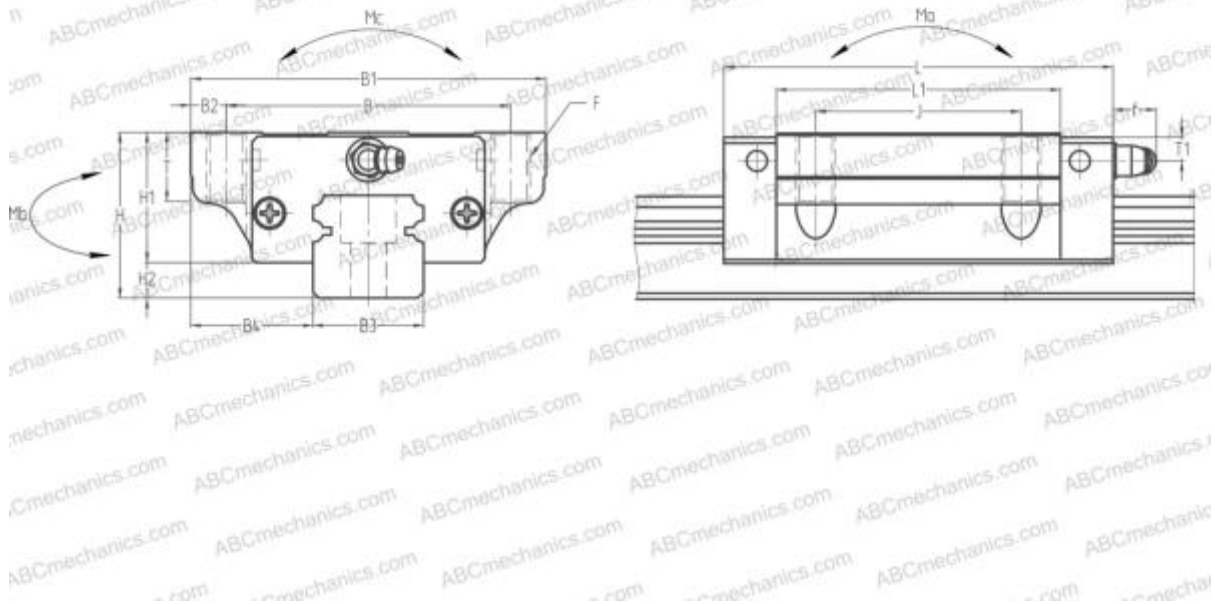

Technical specification

DIMENSIONS, MM

B1	47,000
H	24,000
L	55,000
B	38,000
J	30,000
L1	39,000
B3	15,000
B4	16,000
H1	19,400
H2	4,600
T	8,000
T1	4,500
f	3,300
F	M5x0.8x8

SLIDE WEIGHT

0,170

MANUFACTURER

[NSK](#)

CALCULATION DATA

Basic dynamic load rating, C	10,800 kN
Basic static load rating, Co	20,700 kN
Static permissible moment, Ma	0,094 kN-m
Static permissible moment, Mb	0,079 kN-m
Static permissible moment, Mc	0,108 kN-m