

SSR15XTBY THK

Linear guides

TYPE: Monorail guidance systems, Recirculating balls, High vertical load carrying capacity type, Self-aligning type, Flanged type, Low, Ball slide length - standard, Mounting bolt hole, Compact, Low noise, smooth operation type

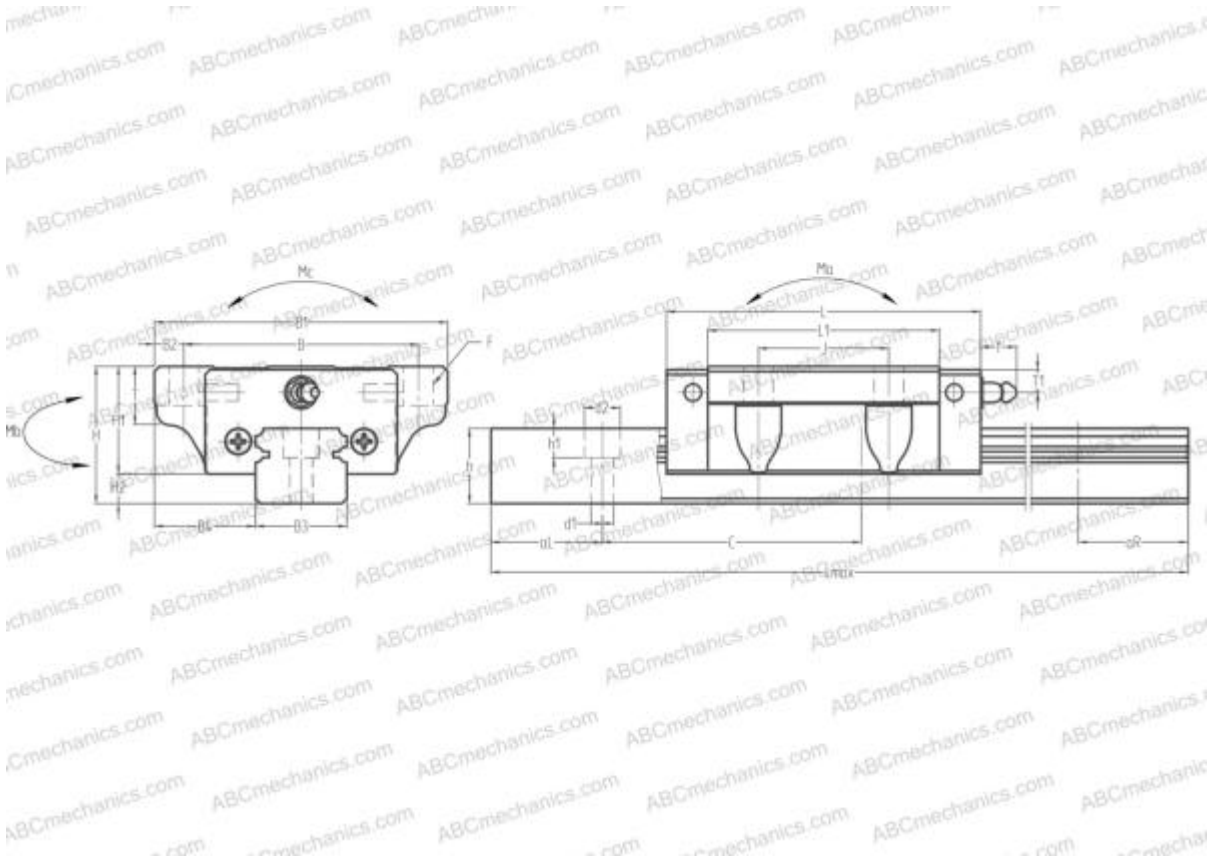

Technical specification

DIMENSIONS, MM

B1	52,000
H	5,300
L	56,800
B	41,000
J	26,000
L1	40,000
D2	7,500
B2	5,500
B3	15,000
B4	18,500
H1	19,400
H2	4,600
T	8,000
T1	6,000
f	3,000

INTERCHANGE

NSK	SS15FL
IKO	LWE15..Q

DIMENSIONS, MM

C	60,000
d1	4,500
d2	7,500
h	12,500
h1	5,300
L max	2000,000
aL	20,000
aR	20,000
F	4.5x7

WEIGHT

Slide weight	0,260
Rail weight	1,400

MANUFACTURER[THK](#)**INTERCHANGE**

ABC	SS15FL
-----	------------------------